

ICW UL90 Installation

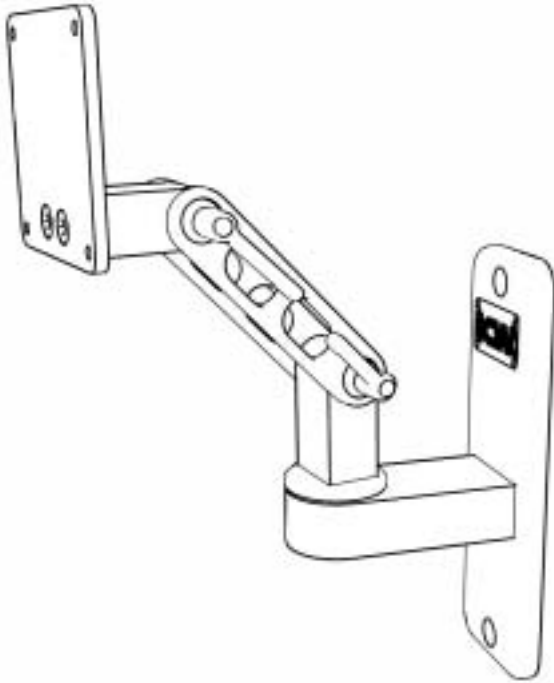

Wall Mount

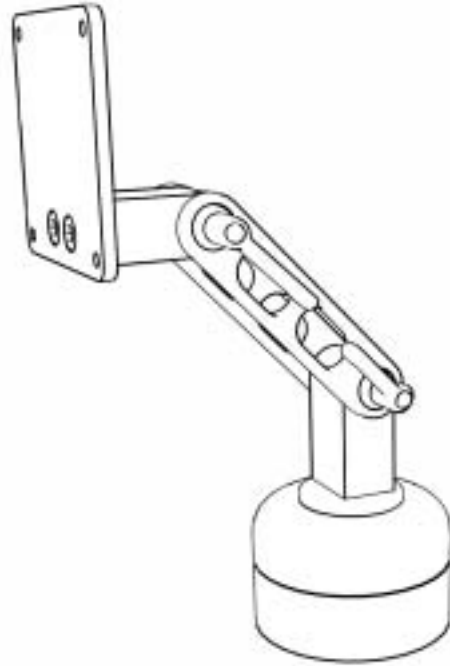

Desk Mount

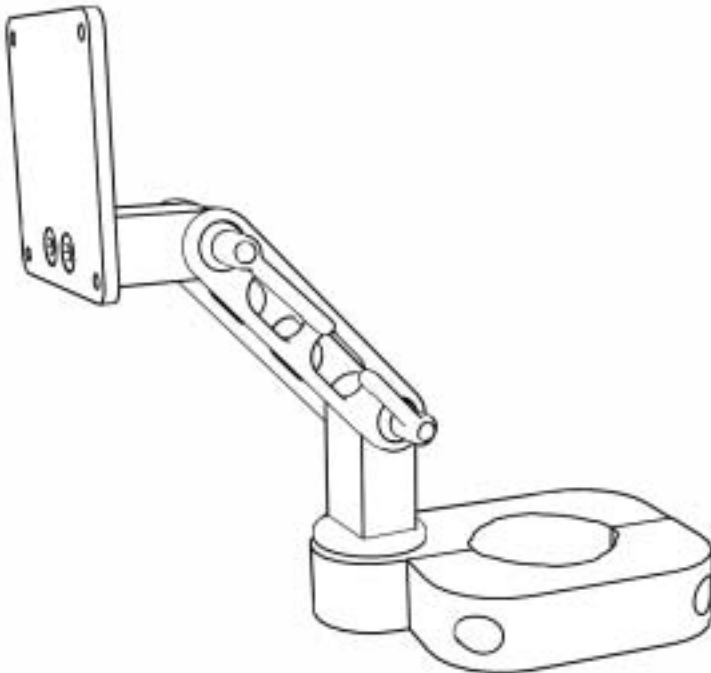

Pole Mount

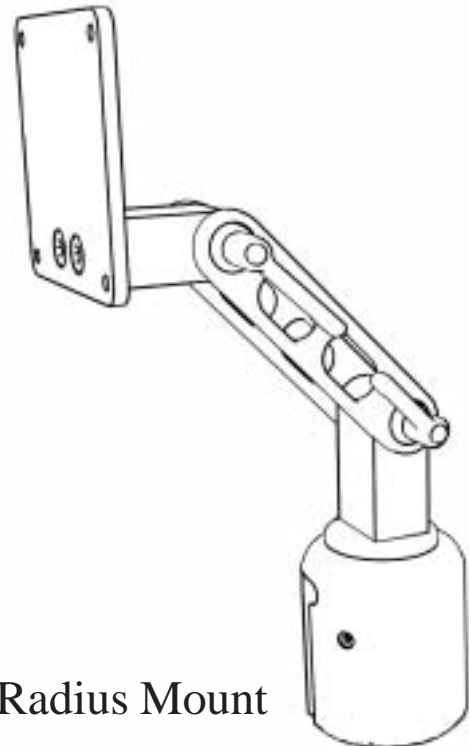

Radius Mount



Wall Mount

Locate the stud in the wall you are mounting to and mark the top hole. Drill 11/64 pilot hole and insert the provided #14 wood screw, tightening slightly. Using a level, mark the lower hole and drill pilot hole, insert the last #14 screw and, with the unit level, tighten both screws.
 Note: ICW supplies #14 wood screws, if installing into metal studs you will need to use proper metal stud fasteners.

If your monitor is over 17" the mount may be more effective if mounted upside down.



Desk Mount

Drill a 3/8 hole through the horizontal surface you intend to mount to and push the 3/8 stud on the desk mount through the hole. Slip the large mounting washer over the stud from underneath and secure in place with the 3/8 nylock.



Screw stud into deskmount.

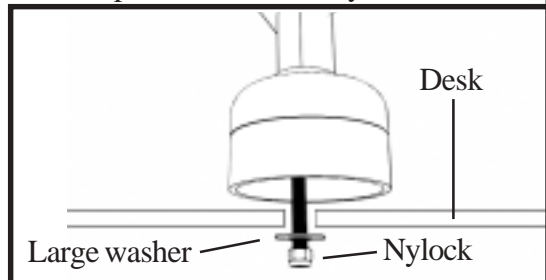

Large washer — Nylock

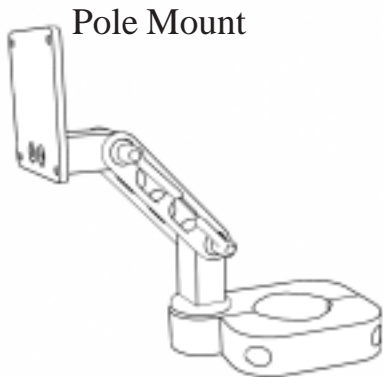

Pole Mount

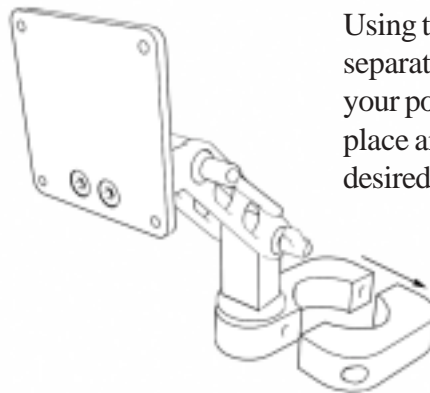

Using the 1/4" hex key, separate the two halves of your pole mount as shown, place around pole at the desired height and reassemble.



Radius Mount

Using a 1/8" hex key, make sure the set screws in the radius mount are pulled out enough that the mount will easily slide down over the pole. Then retighten set screws.

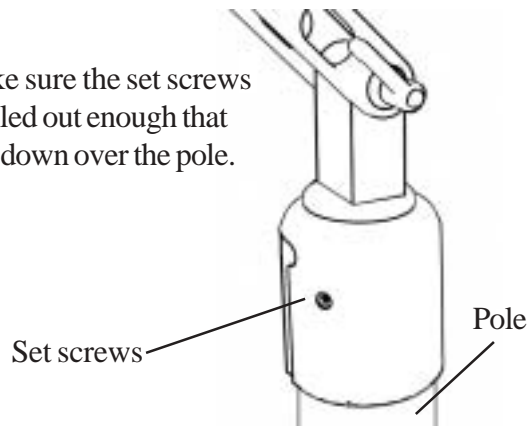

Set screws — Pole

Mount the Vesa plate to the friction mount using the 5/32" hex key and the 1/4-20 flat-head screws in your hardware bag.

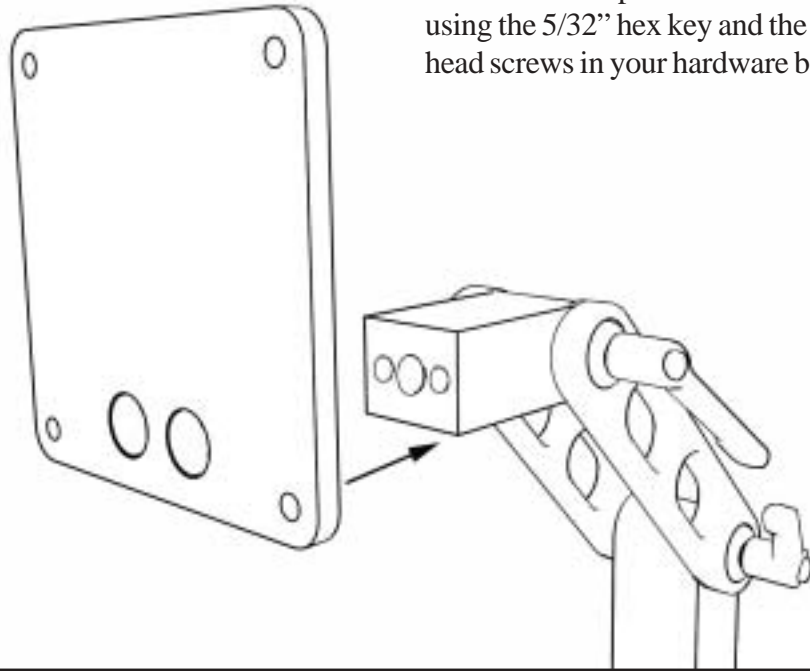

Attach your monitor to the ul90 using the 4mm screws in your hardware bag.

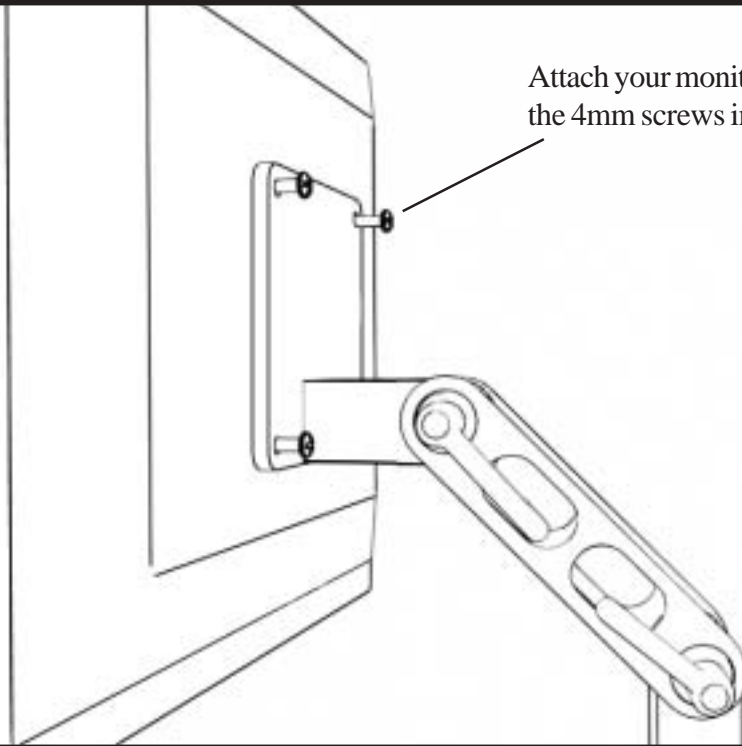

Use the handles to adjust the tilt of your monitor.

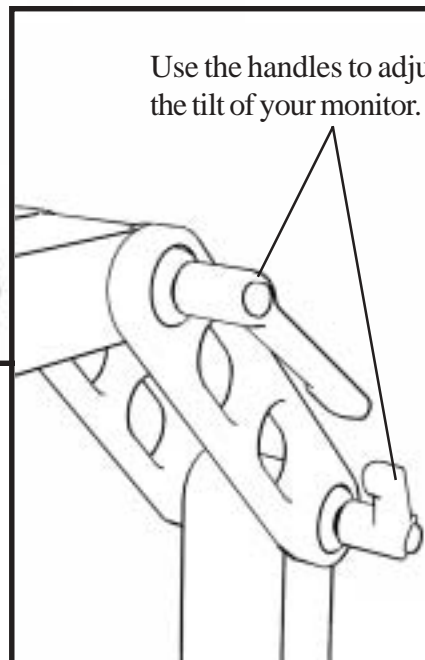

Thank you for your purchase of an ICW UL90 monitor mount.

Any questions please contact ICW at: 1-800-558-4435