

The Ultra 390 Series

Installation instructions for the Ultra 390 track slider series.
II013 Revision B. 2-21-03 MF

INSTALLATION INSTRUCTIONS



Locate the wall stud and mark the top hole of the Wall Track, drill 11/64 pilot hole and insert #14 screw and tighten slightly. Use a level, mark the lower holes, drill pilot holes and then insert the #14 screws, again making sure the unit is level. **NOTE 1:** ICW supplies # 14 Wood screws. If installing into metal studs, you will need to replace these with proper metal stud fasteners.

Remove small socket head cap screw in the top middle of the Wall Track.

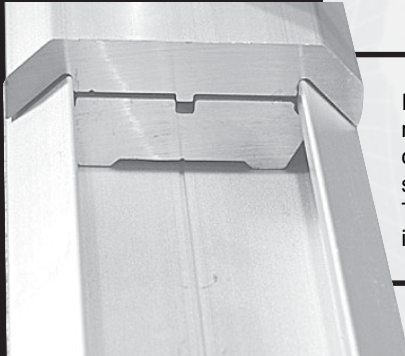

Insert the Slider into the Wall Track as shown right and replace the small socket head cap screw. If you have chosen to mount your LCD underneath the arm assembly simply turn the Slider upside down and insert into the Wall Track. You cannot mount the LCD under the arm assembly if the Keyboard option is used.

Once you have adjusted the slider to the desired height, tighten down the track slider using the handle on the slider as shown.



UL90 to VESA



Using the 5/32" hex key wrench, attach the VESA plate to the friction mount. **To mount the monitor lower** you can also mount the VESA upside down with the screw holes at the top. Using a phillips screw driver, attach the VESA plate to the back of your LCD monitor.

MONITOR

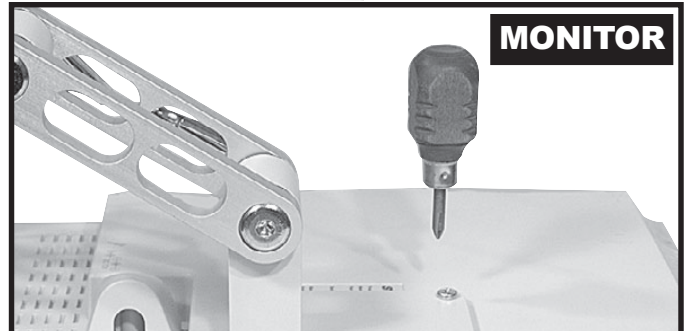

KEYBOARD

Install the keyboard using the five 10/24 stainless screws supplied.

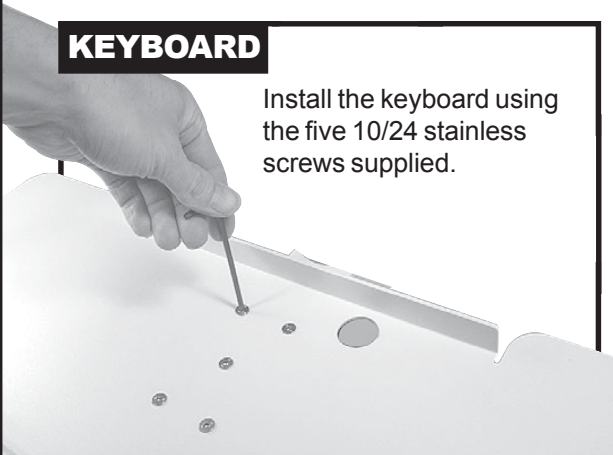

ADJUST TILT

Adjust the tilt of your flat panel monitor using the handles on the right side of the friction mount.

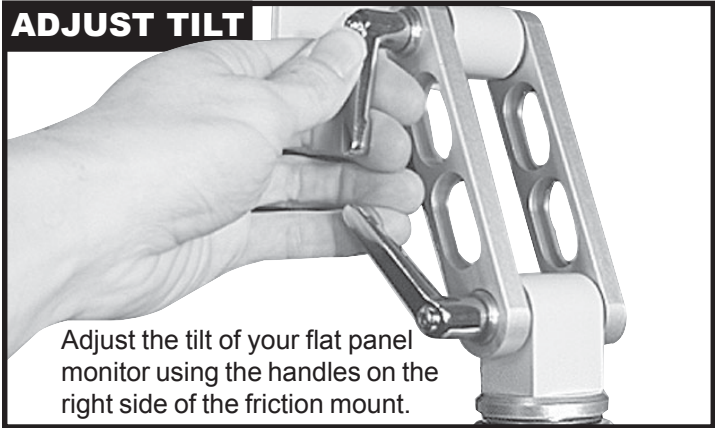

CORD MANAGEMENT

Turn the arm assembly upside down and lay on a flat surface. Take all the cables you wish to install and lay flat beside the arm assembly. Using nylon wire ties or electricians tape, make a harness out of the cabling. Make sure to form it in such a way as to fit the cable cutout. Remove the 4 screws on either side of the cable channel, place your cords in the channel and press the plastic cover in over the cords. Replace the 4 screws.



TIGHTEN JOINTS

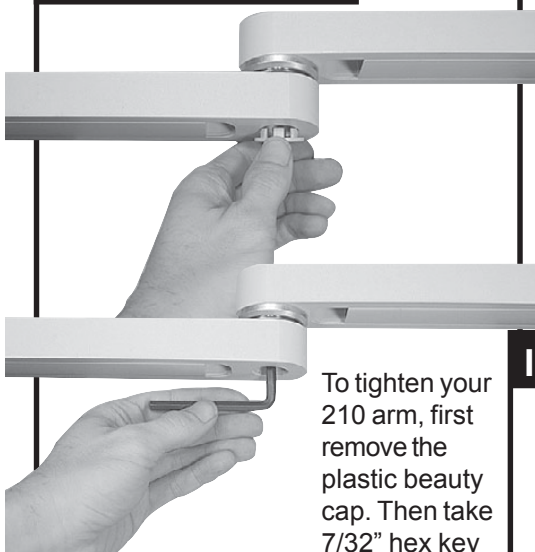

To tighten your 210 arm, first remove the plastic beauty cap. Then take 7/32" hex key wrench provided and tighten the bolt that connects the arms.

KEYBOARD FLIP

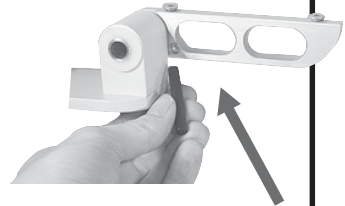
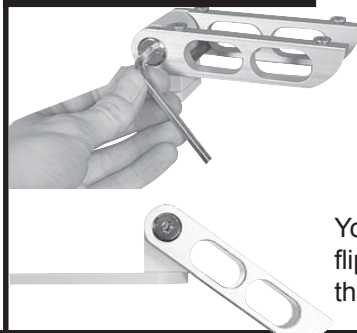

You can make your keyboard flip-up fold down by taking out the stop pin as shown.

Included hardware:

- 1/8" hex key wrench
- 5/32" hex key wrench
- 5mm hex key wrench
- 7/32" hex key wrench
- 4 wood screws
- 4 - 4mm screws with phillips drive
- VESA plate(s)

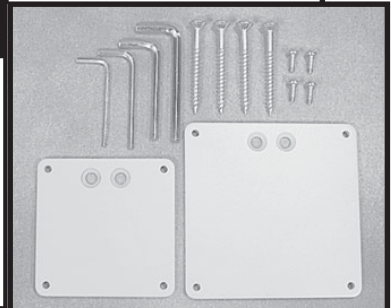

the Ultra 390 track slider

UL390TSQ1-0-3

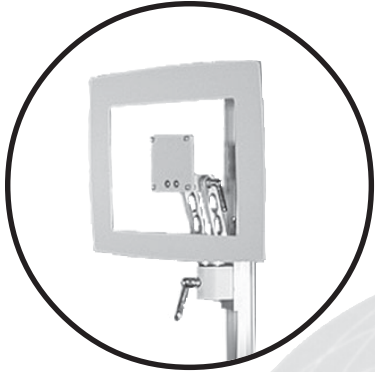

Though we recommend that you mount the monitor slider with the monitor under the slider you can choose to mount it either way.

UL390TSQ1-0-3-1



UL390TSQ1-0-3-2



UL390TSQ1-0-3-3



the Ultra 390 track slider

UL390TSQ1-0-1

Though we recommend that you mount the monitor slider with the monitor under the slider you can choose to mount it either way.

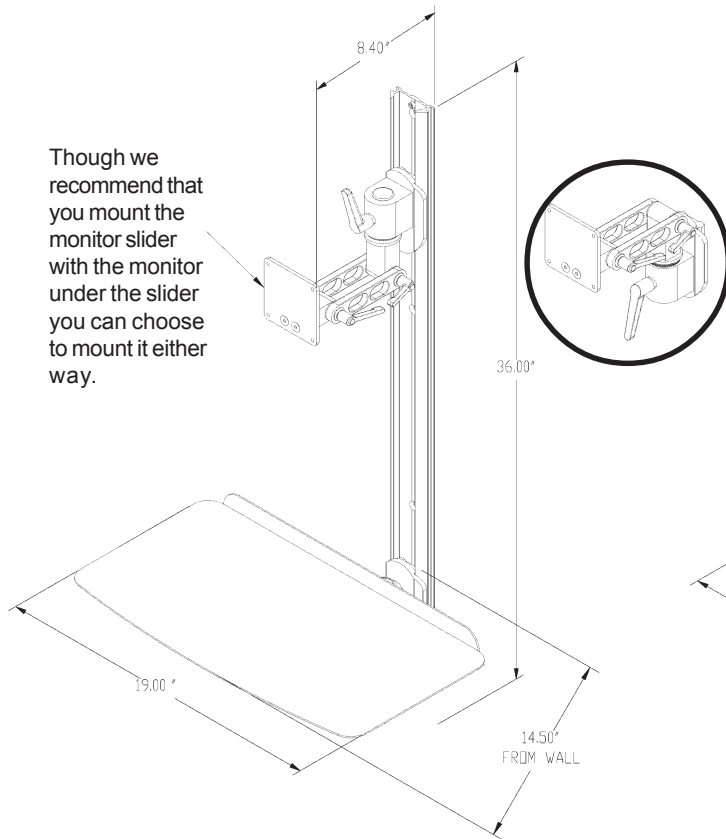

UL390TSQ1-0-1-1

Though we recommend that you mount the monitor slider with the monitor under the slider you can choose to mount it either way.

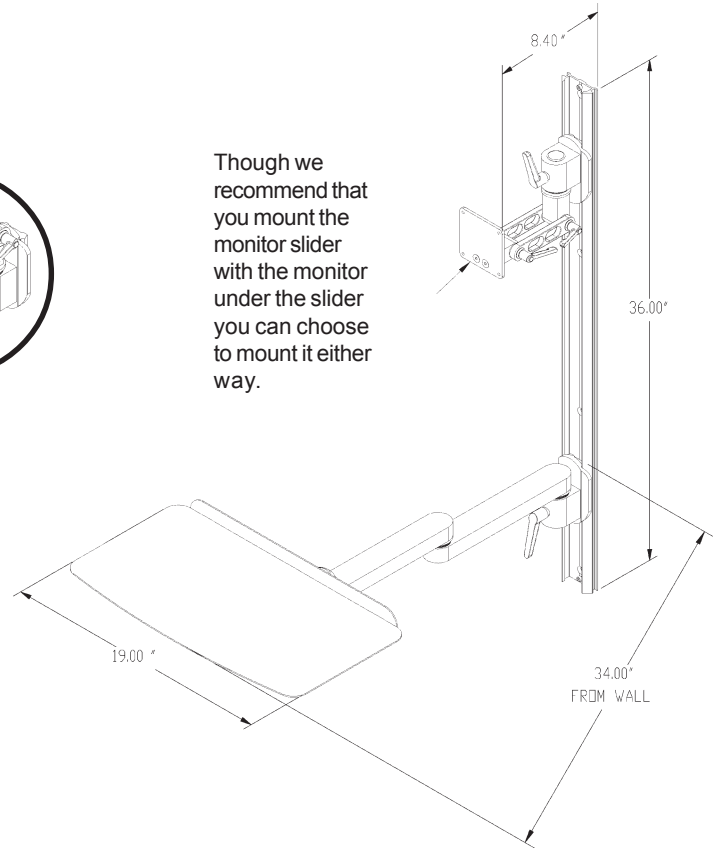

UL390TSQ1-0-1-2

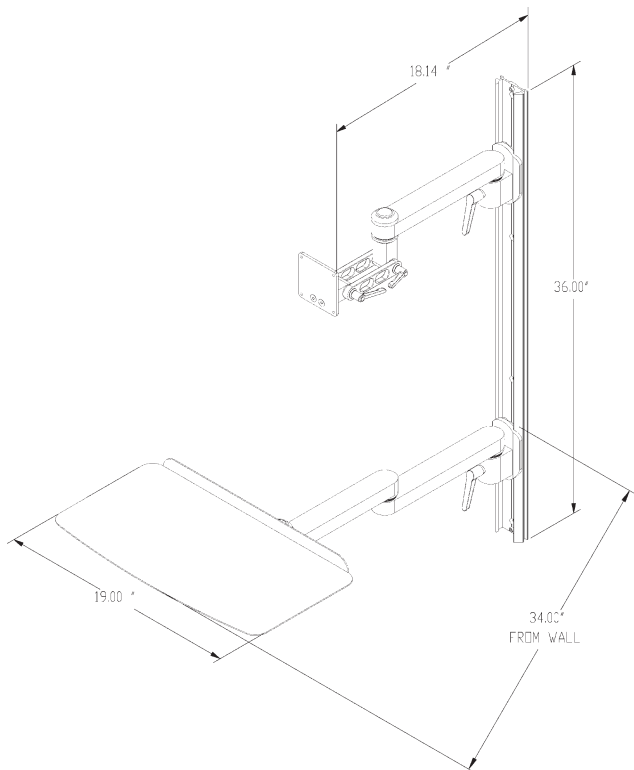

UL390TSQ1-0-1-3

